

Key Features

- Internal sensor
- Over-speed or under-speed configuration, 1-990 rpm
- 1 DPDT relay output (SCP1000), 2 SPDT relay outputs (SCP2000)
- Visual setpoint adjustment with digital accuracy
- Built-in start delay
- Dial-in calibration does not require power
- 115, 230 VAC (50-60 Hz) and 12, 24 VDC power options
- Works with Electro-Sensors magnetic pulser discs / wraps
- Optional EZ-SCP mounting bracket and Mounting Magnet
- Cast aluminum explosion proof (XP) housing
- UL Listed Class I, Div I (C, D) Class II, Div I (E, F, G)



Description

SCP1000 and SCP2000 presettable speed switches are self-contained shaft rotation monitoring systems providing one or two individually adjustable relay setpoints. They are ideal for use in hazardous and wet locations where monitoring speed for alarm or machinery shutdown is critical for safe operation, such as for over-speed and / or under-speed protection on bucket elevators, fans/ blowers, screw conveyors, rotary airlocks or virtually any rotating shaft. SCP series switches feature visual setpoint adjustment via rotary dials for ease and accuracy, and all calibration can be done with the machinery at rest.

SCP series switches are offered as standard in two configurations: a single relay output (SCP1000) or a dual relay output (SCP2000). The SCP2000 can provide additional relay protection such as bracketing the operating speed with one over-speed and one under-speed setpoint. In many industries the SCP2000 is commonly utilized with both relays set in under-speed mode; the first relay provides warning of a slowdown, and also permits interlock wiring to shut down auxiliary machinery. If the shaft continues to slow down and reaches the second setpoint, the primary process can be wired for shutdown, maintaining the efficiency and safety of operations by preventing machine damage, product waste, and costly downtime.

Principle of Operation

The SCP1000 and SCP2000 measure shaft speed by sensing magnets embedded in a pulser disc* attached to the rotating shaft end or a split collar pulser wrap* attached around the shaft. SCP series speed switches are supplied with an easily adjustable mounting bracket assembly. The gap distance between the speed switch and disc or wrap is $1/4" \pm 1/8"$. You only need a ruler to position our sensing heads (with our competitors you need a feeler gauge).

The rotating shaft **1** with an end mounted pulser disc* **2** or a split collar pulser wrap* **3** creates a rotating magnetic field **4** that is detected by the Hall Effect sensor in the Shaft Speed Switch **5**. If the rotation speed detected is below the user-adjusted setpoint(s), the output relay(s) de-energizes, providing an alarm signal or equipment shutdown.

* Sold separately. See System Options for part numbers.

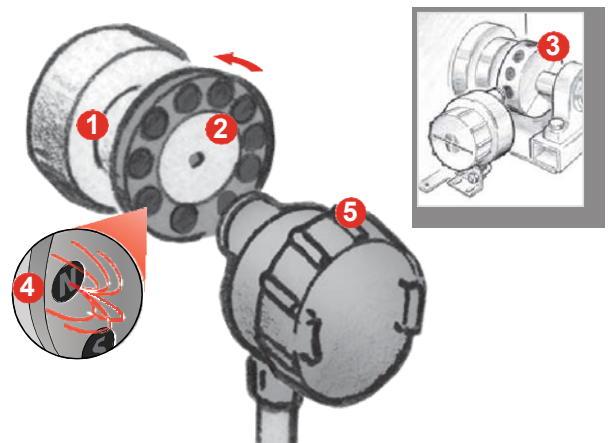

SCP1000 / SCP2000 Specifications

	SCP1000	SCP2000
Detection (selectable)	Under-speed, Over-speed, Zero Speed	
Operating		
Input Power Options	115 VAC (60 Hz), 230 VAC, 12 VDC, 24 VDC	
Maximum Frequency	266.66 Hz	
Gap Distance	1/4" ± 1/8"	
Operating Temperature	-40° F to +140° F	
Setpoint Data		
Number of Setpoints	1	2
Setpoint Range (RPM)	1-99	10-999
Contact Arrangement	1 DPDT Form C	2 SPDT Form C
Setpoint Accuracy	±0.5%	
Setpoint Adjustment	Rotary Switches (tens and ones digit)	
Hysteresis	6%	
Relay Contact Rating	Isolated, 5 Amp, 250 VAC, 30 VDC Resistive	
Start Delay Option	✓	
Housing		
Enclosure Mount	1-Inch NPT Conduit Opening	
Material	Cast Aluminum	
Enclosure Rating	NEMA 4X, Meets NEMA 1, 3, 12, 13, and NEMA 7, 9	

Specifications subject to change without notice.

Ordering

All models come with a standard bracket for mounting

Model Description	Part Number
SCP1000, 115 VAC - Standard	800-020100
SCP1000, 230 VAC	800-021100
SCP1000, 12 VDC	800-023100
SCP1000, 24 VDC	800-022100
SCP2000, 115 VAC - Standard	800-040100
SCP2000, 230 VAC	800-041100
SCP2000, 12 VDC	800-043100
SCP2000, 24 VDC	800-042100

SCP1000 / SCP2000 Standard System

- Shaft Speed Pulse Generator

These are the most popular system components. Many other options are available.

System Options	Part Number
Standard 255 Nylon Pulser Disc, 4" Diameter, 16 Magnets	700-000200
Split Collar Pulser Wrap (PVC, Aluminum, Stainless Steel)	Custom (See Website)

Other Options	Part Number
EZ-SCP Bracket Assembly w/255 Disc & U-bolt	810-000005
EZ-SCP Bracket Assembly with U-Bolt	810-000006
MM-2.00 Mounting Magnet (For use with EZ-SCP Bracket Assembly)	810-000050
EZ-SCP w/232 Disc	810-000032
Standard Disc Guard	725-005300
EZ-SCP Disc Guard	725-005600
PTU-1000 Test Unit (simulates unwanted conditions for testing purposes)	800-033000



EZ-SCP Mounting Option



MM-2.00 Mounting Magnet Option (must be used with EZ-SCP)



Standard Disc Guard



EZ-SCP Disc Guard



PTU-1000 Test Unit (all SCP models have a jack)

Customization

If one of our standard products does not meet your specifications, please call one of our applications specialists. Many of our products can be customized to fit specific needs.

Additional Information

See SCP1000/SCP2000 Installation and Operating Manual for complete details, specifications, and programming instructions.